

Glass silk heating tape (for non hazardous area use)

S45 is a preterminated, flexible heating tape consisting of a glass silk insulated, flexible fabric weave with interior heating conductors. The protective overbraid of the coiled heating conductors meets the requirements of Protection Class I.

The temperature depends on the power and way of use. Please make sure that the heating tape does not exceed the maximum withstand temperature. Owing to its handy dimensions, the heating tape is used for heating up and com-

pensating heat losses on short pipes and small-sized structures. The heating tape is not moisture-protected and must only be used in dry areas.

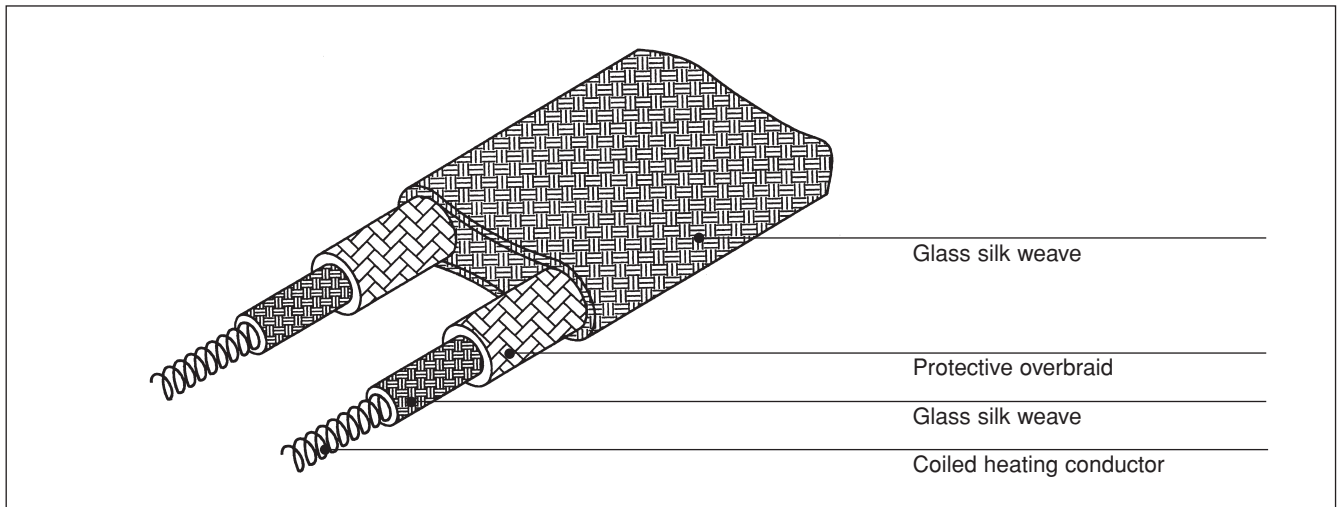

Size Approx. 30 mm wide x 5 mm thick (approx. 1.2" x 0.2")

Specification

Nominal power output	250 W/m (76 W/ft)
Supply voltage	230 V AC
Loading tolerance	Up to 100 watts \pm 10%, from 100 watts + 5% / - 10%
Area classification	Non hazardous
System of protection	IP 20, no protection against ingress of water
Electrical protection	Class I
Max. withstand temperature (power off)	450°C (842°F)
Max. surface temperature (power on)	Up to 450°C (842°F) (power and way of use dependent)
Bending radius	\geq 15 mm (0.6")
Spacing	\geq 5 mm (0.2")

Construction

Heating element	Coiled, NiCr
Electrical insulation	Braided with glass silk and protective overbraid, CuNi-plated
Outer sheathing	Glass silk
Termination	Mounting loop \varnothing 8 mm

Termination

Cold lead	1.0 m (3.3 ft)
Terminating tails	60 mm / 1.5 mm ² (2.4" / AWG 16)

Standard lengths and loadings table

	Length m (ft)	Watts	Volts	Part No.
	0.5 (0.15)	100	230	386 552-000
	1.0 (0.3)	250	230	542 364-000
Other lengths and power specifications etc. available upon request	1.5 (0.46)	375	230	051 330-000
	2.0 (0.61)	500	230	111 280-000
	2.5 (0.76)	625	230	870 574-000
	3.0 (0.9)	750	230	873 740-000
	4.0 (1.2)	1000	230	596 276-000
	5.0 (1.5)	1250	230	932 450-000

Ordering details

Part description	S45
Part No.	See table above

Isopad – a brand of Tyco Thermal Controls GmbH.

www.isopad.de
www.tycothermal.com

Important: All information, including illustrations, is believed to be reliable. Users, however, should independently evaluate the suitability of each product for their particular application. Tyco Thermal Controls makes no warranties as to the accuracy or completeness of the information, and disclaims any liability regarding its use. Tyco Thermal Controls' only obligations are those in the Tyco Thermal Controls Standard Terms and Conditions of Sale for this product, and in no case will Tyco Thermal Controls or its distributors be liable for any incidental, indirect or consequential damages arising from the sale, resale, use or misuse of the product. Specifications are subject to change without notice. In addition, Tyco Thermal Controls reserves the right to make changes, without notification to the Buyer, to processing or materials that do not affect compliance with any applicable specification.

tyco

Flow Control

Tyco Thermal Controls

We manage the heat you need

Tyco Thermal Controls GmbH
 Englerstr. 11
 D-69126 Heidelberg
 Phone +49(0)6221-3043-0
 Fax +49(0)6221-3043-956

Tyco Thermal Controls
 Staatsbaan 4A
 B-3210 Lubbeek
 Phone +32(0)1621-3511
 Fax +32(0)1621-3600

Tyco Thermal Controls Limited
 3 Rutherford Road,
 Stephenson Industrial Estate,
 GB-Washington,
 Tyne and Wear NE37 3HX
 Phone +44(0)191 419 8200
 Fax +44(0)191 419 8201

Worldwide Headquarters Tyco Thermal Controls
 300 Constitution Drive,
 Menlo Park,
 CA 94025-1164, USA
 Phone (800) 545-6258
 Fax (800) 545-5004